

The Mini Coax allows multi-pole coaxial data transmission for board-to-board, cable-to-board and cable-to-cable applications with protection up to IP 65 / IP 67. At the same time, applications up to 2.5 GHz are open on the basis of 50 Ohm. Straight and angled contact inserts in press-in technology are available for device integration.

HARTING assembles Mini Coax connectors with the matching cable type according to customer specifications in order to guarantee top performance of the transmission lines. A special feature is the connector overmolding, which guarantees a top quality and robust connection between the cable and connector.

### Application profile:

CONNECTION TYPE		ENVIRONMENT		APPLICATION						
Board to Board	Cable/Wire to Board	IP 20	IP 65 / IP 67	Data	Signal	Power	high performance			
							Data transfer rate	Shielding	Number of contacts, contact density	Voltage, working current
<input checked="" type="checkbox"/>	<input checked="" type="checkbox"/>	<input checked="" type="checkbox"/>		<input checked="" type="checkbox"/>	<input checked="" type="checkbox"/>		<input checked="" type="checkbox"/>	<input checked="" type="checkbox"/>		
Cable termination			PCB termination			Application standard				
<i>Han-Quick Lock®</i>	<i>IDC</i>	<i>Crimp</i>	<i>THT</i>	<i>SMC</i>	<i>SMT</i>					
<input type="checkbox"/>	<input type="checkbox"/>	<input checked="" type="checkbox"/>	<input type="checkbox"/>	<input type="checkbox"/>	<input type="checkbox"/>					
<i>Screw</i>	<i>Cage clamp</i>	<i>Axial screw</i>	<i>Press-in</i>							
<input type="checkbox"/>	<input type="checkbox"/>	<input type="checkbox"/>	<input checked="" type="checkbox"/>							
<i>Separate housing</i>	<i>Integrated housing</i>									
<input checked="" type="checkbox"/>	<input type="checkbox"/>									

CONTENTS	PAGE
Mini Coax connector system – introduction	10.02
Mini Coax connector system – general information	10.04
Technical characteristics	10.06
Straight Mini Coax Standard modules for backplane assembly	10.08
Angled Mini Coax Standard modules for daughtercard assembly	10.09
Angled Mini Coax low-profile modules for daughtercard assembly	10.10
Angled Mini Coax single-row modules for daughtercard assembly	10.11
Mini Coax cable assemblies – general information	10.12
Assemblies with standard and low-profile modules	10.13
Assemblies with single-row modules and with heavy duty hoods/housings	10.14
Accessories	10.15

Mini Coax tooling see chapter 20

Mini  
Coax

## MULTI-COAXIAL CONNECTOR SYSTEM MINI COAX

The HARTING multi line Mini Coax connector system for board-to-backplane RF interconnection includes connectors for press-in technology with 1 to 10 coaxial lines.

The Mini Coax connector range allows transmission of analogue signals in various applications like cellular base transceiver stations (BTS), repeaters and passenger entertainment systems at radio frequencies up to 2.5 GHz per line at 50 Ohm.

Moreover, these compact and rugged connectors provide a 6 Sigma mating reliability thanks to the closed-entry contact design. The compact size of Mini Coax modules (minimum pitch of RF lines is 4.4 mm), combined with excellent RF-performance,

makes this connector system especially suitable for high-end equipment.

The twin modules are available in metric sizes of 1.00, 1.25 and 1.50 SU (SU = System Unit = 25 mm) for both cable assemblies and PCBs with 2 to 10 coaxial lines, as well as a single row version with 1 to 3 coaxial lines.

HARTING offers customised cable assemblies including adaptor cables to the most popular discrete coaxial contacts such as SMA, SMB, BNC, N-Type, etc. A complete range of accessories and tools supports the wide product range.

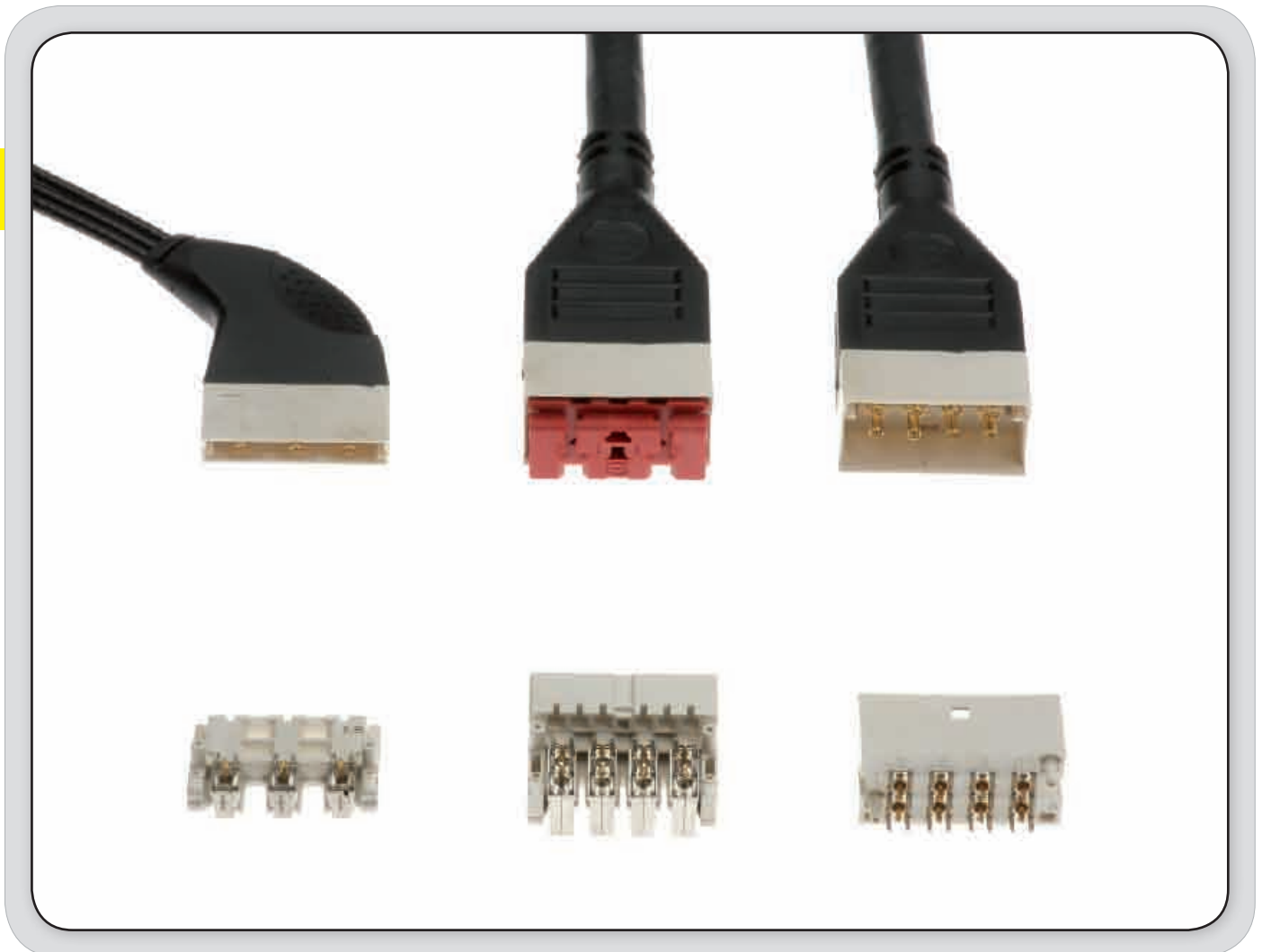

Mini  
Coax

## CAN BE USED IN MIXED CONFIGURATION

As board-to-board connectors Mini Coax and *har-bus*<sup>®</sup> HM connectors can be used on board in any mixed configuration.

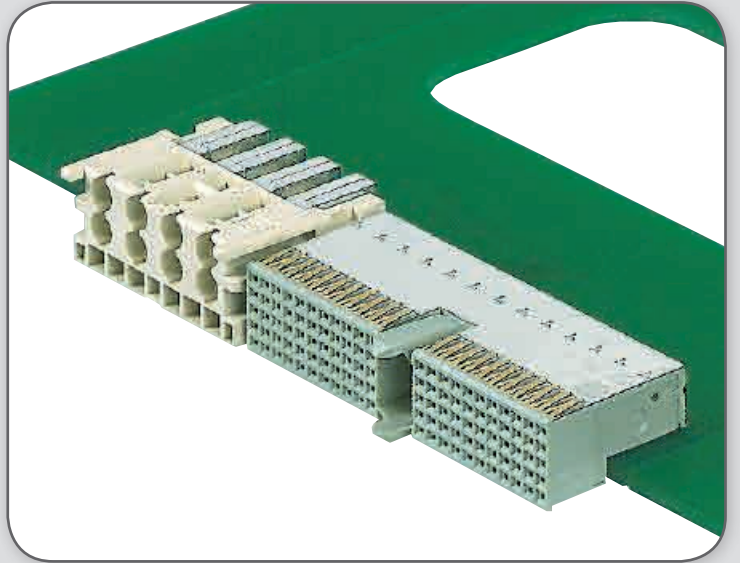

## HIGH TRANSMISSION RATE

Due to the combination of soldering principles SMC and SMT, a Mini Coax+ connector offers the best transmission characteristics up to 4 GHz and robust design.

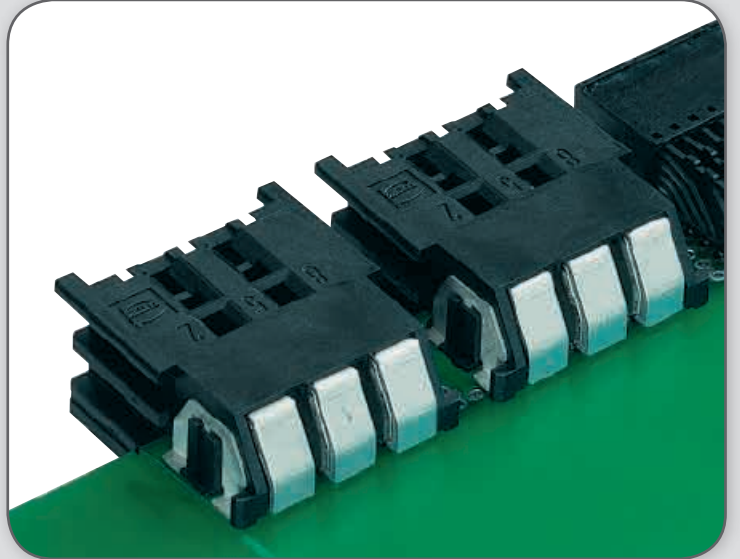

## IP 65 ENVIRONMENT

The combination of a Mini Coax connector with a Han<sup>®</sup> housing results in a proper IP 65 Industrial Mini Coax connector.

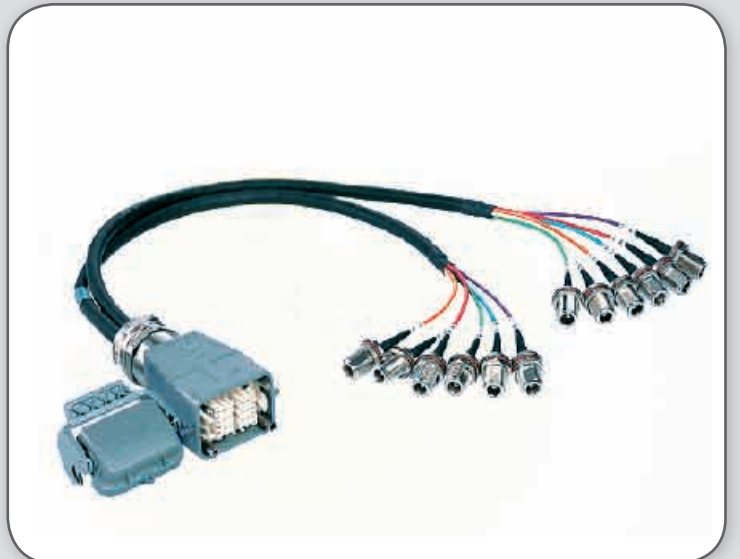

The Mini Coax connector is a multi line RF connector for blind mating of board-to-board, board-to-cable or cable-to-cable applications. The Mini Coax connector is mainly used in both RF (Radio Frequency) and IF (Intermediate Frequency) signal transmission and is specified for a frequency range from DC to 2.5 GHz and beyond. Thanks to its compact size (a 10 coaxial lines' connector is as small as a PC's enter key) and excellent crosstalk features, this connector system is ideal for high end equipment within cellular telecom infrastructure.

The isolated coaxial lines are implemented in a plastic housing that defines the module size in a metric scale from 1.00, 1.25 and 1.50 SU (SU = System Unit = 25 mm). The Mini Coax connectors are available as straight sockets and right angled plugs. Both types are executed in press-in technology for the PCB (Printed Circuit Board) termination. The straight modules are delivered with an inserted plastic cap that protects the coaxial

contacts against dust and dirt, as well as being used as an upper press-in tool. In this way, an easy and safe flat rock process is guaranteed.

In addition to the coaxial modules, an angled power connector with press-in termination is available. It is assembled in the same board drillings as the coaxial configuration, and can be loaded up to 15 A working current at 70 °C.

The low-profile Mini Coax right angled board connector and matched cable assemblies have the same RF performance as the standard Mini Coax connectors. Their slim interfaces, which provide a board-to-cable solution for the slim cabinet, are suitable for a minimum 15.2 mm slot width.

The Mini Coax single-row is another new development. The coaxial contacts of the connector are single line, as opposed to the standard connector. This delivers enhanced performance, especially in terms of isolation, and is also suitable for slim cabinet applications.

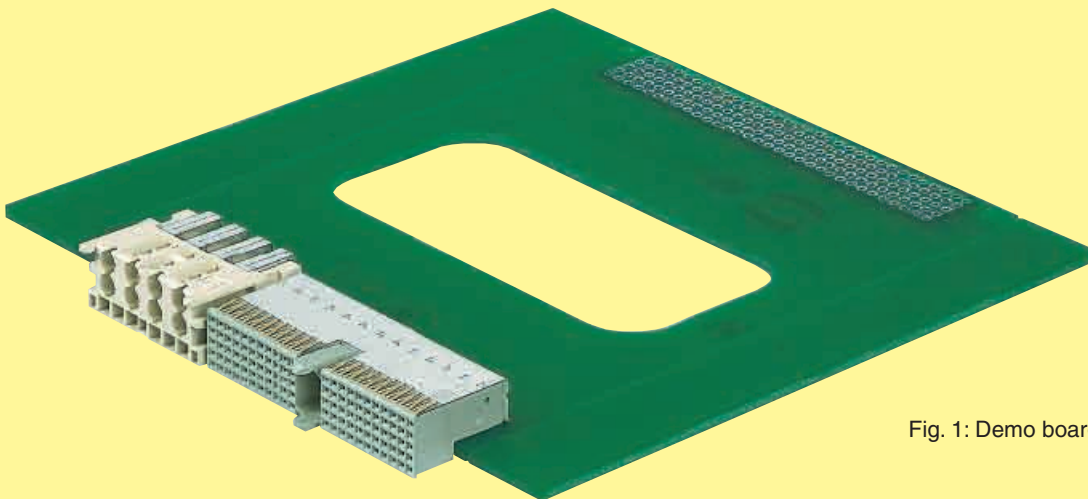

Fig. 1: Demo board

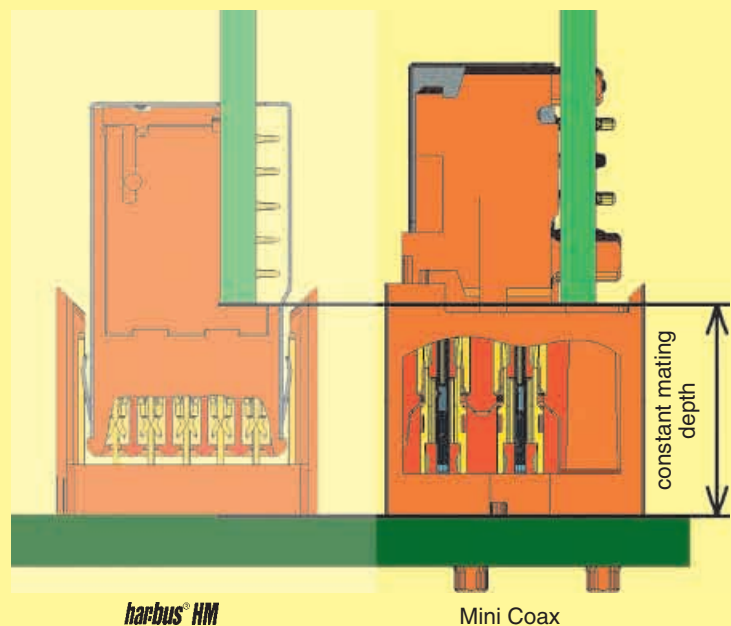

Fig. 2: Cross section of both connector types

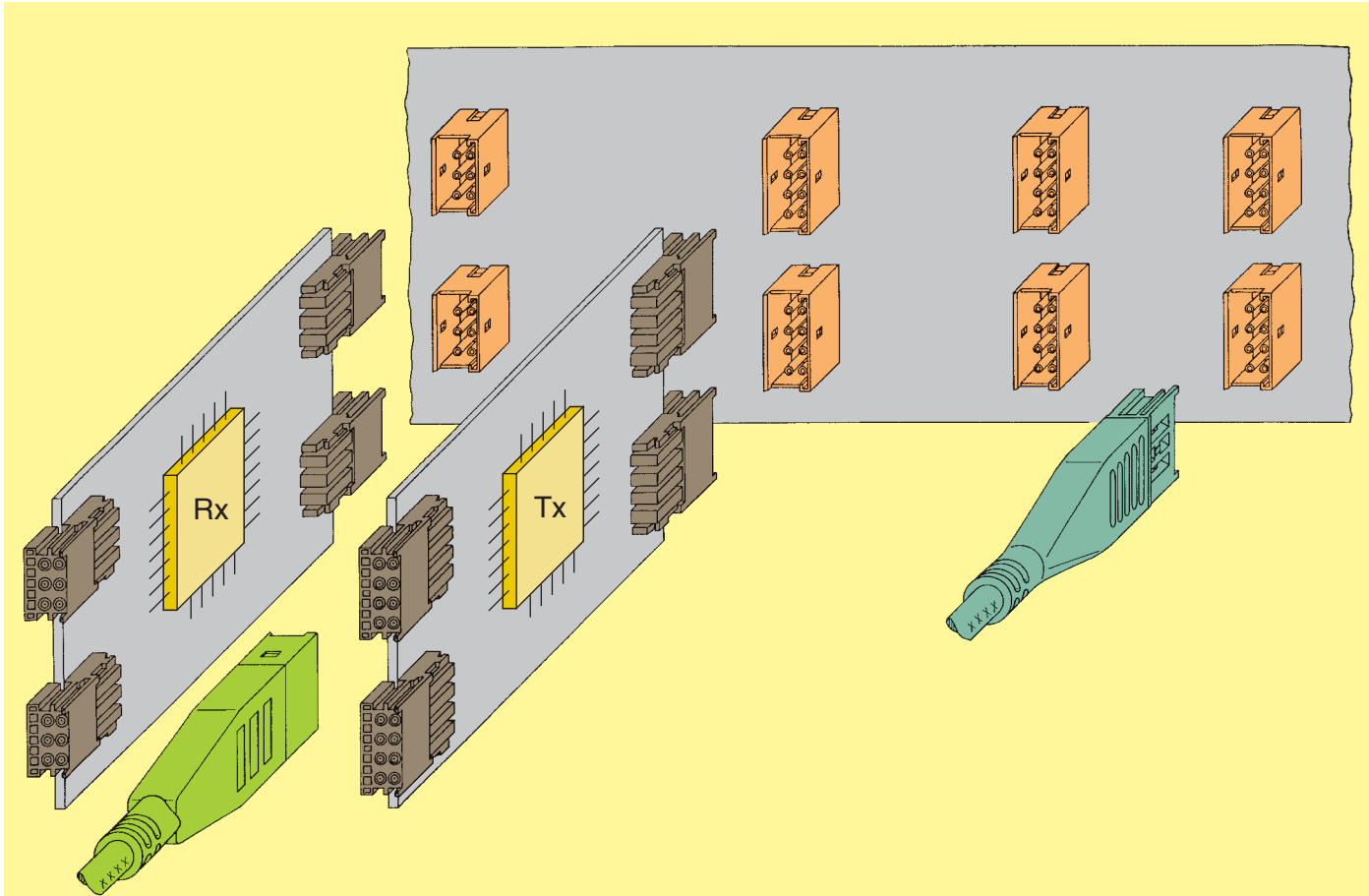

Fig. 3: Typical pcb configurations

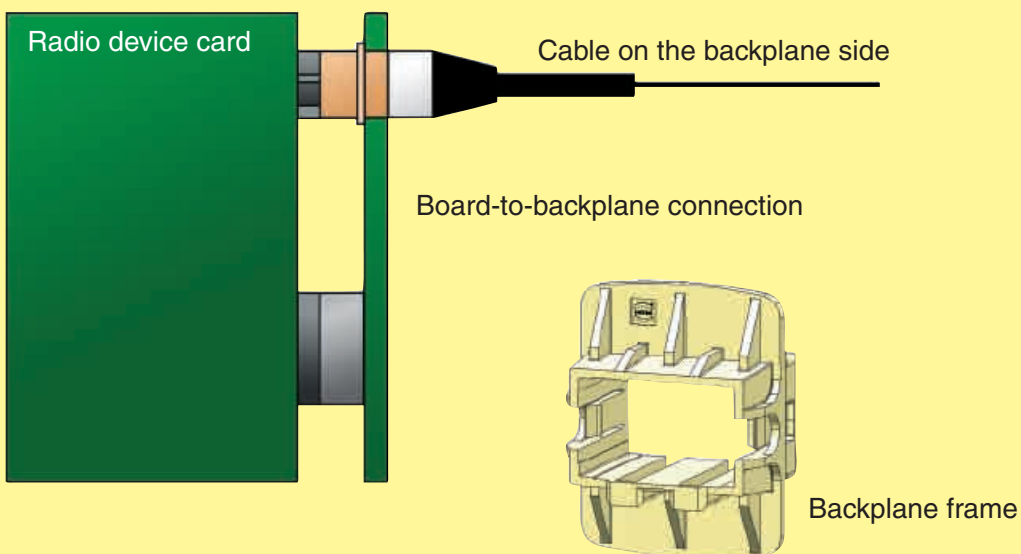

Fig. 4: Mini Coax backplane feed through

Number of contacts : 1, 2, 4, 6, 8 or 10 coaxial contacts  
 Grid pattern : 4.40 x 6.25 mm (within a twin x between twins);  
 8.80 mm for Mini Coax single-row connectors

Dielectric withstanding Voltage  $U_{r.m.s.}$  :  $\leq 1000$  V (for 60 s)  
 DC-contact resistance  
     Centre contact :  $\leq 12$  m $\Omega$   
     Ground contact :  $\leq 6$  m $\Omega$   
 Insulation resistance :  $\geq 5000$  M $\Omega$

Power :  $\leq 40$  W (at 2.5 GHz)  
 Frequency range : DC ... 2.5 GHz  
 Nominal impedance : 50  $\Omega$   
 Return loss :  $< -20$  dB  
 VSWR :  $< 1.22$   
 Insertion loss :  $< 0.25$  dB

Near end crosstalk (NEXT) :	Pin distance	Board-to-Board	Board-to-Cable	Cable-to-Cable
	$\Delta x = 4.40$ mm	50 dB	60 dB	90 dB
	$\Delta x = 6.25$ mm	60 dB	70 dB	90 dB
	$\Delta x = 7.64$ mm	75 dB	80 dB	90 dB
	$\Delta x = 8.80$ mm	–	75 dB	–
	$\Delta x = 12.50$ mm	90 dB	90 dB	90 dB

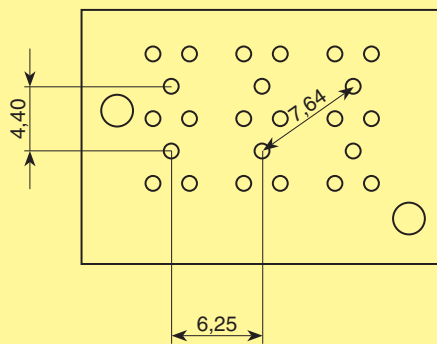

Fig. 5: Grid pattern  
Mini Coax Standard

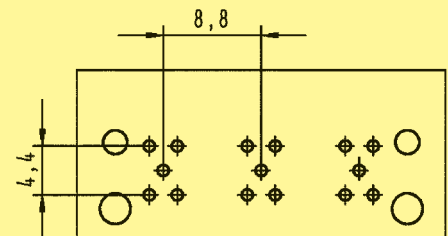

Fig. 6: Grid pattern  
Mini Coax single-row

Temperature range :  $-55$  °C ...  $+125$  °C

Moulding material : Liquid Cristal Polymer (LCP), UL 94-V0  
 Contact surface  
     Contact zone : Au  
     Termination area  
         Centre pin : Au  
         Ground pin : Ni

Mating cycles : max. 500

Recommended configuration of plated through holes :

<i>Tin plated PCB (HAL)</i> <i>acc. EN 60352-5</i>	Hole-Ø	1.15 <sup>±0.025</sup> mm
	Cu	min. 25 µm
	Sn	max. 15 µm
	Plated hole-Ø	0.94-1.09 mm
<i>Chemical tin plated PCB</i>	Hole-Ø	1.15 <sup>±0.025</sup> mm
	Cu	min. 25 µm
	Sn	min. 0.8 µm
	Plated hole-Ø	1.00-1.10 mm
<i>Au / Ni plated PCB</i>	Hole-Ø	1.15 <sup>±0.025</sup> mm
	Cu	min. 25 µm
	Ni	3-7 µm
	Au	0.05-0.12 µm
	Plated hole-Ø	1.00-1.10 mm
<i>Silver plated PCB</i>	Hole-Ø	1.15 <sup>±0.025</sup> mm
	Cu	min. 25 µm
	Ag	0.1-0.3 µm
	Plated hole-Ø	1.00-1.10 mm
<i>OSP copper plated PCB</i>	Hole-Ø	1.15 <sup>±0.025</sup> mm
	Cu	min. 25 µm
	Plated hole-Ø	1.00-1.10 mm

PCB board thickness: ≥ 1.6 mm

Mating force : ≤ 5 N/line

Withdrawal force : > 1 N/line

Mating distance : 12.5 ... 15 mm

Wiping length : 2.5 mm

Acceptable radial mating offset : max. ± 1.5 mm



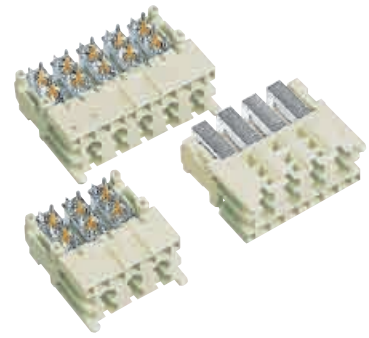

## Angled modules

Identification	Number of contacts	SU	loaded positions	Part number
Mini Coax modules, press-in termination	10	1.50	2, 5, 8, 11, 14	07 31 100 0021
	8	1.25	2, 5, 8, 11	07 31 100 0020
	6	1	2, 5, 8	07 31 100 0019
	4	1	2, 8	07 31 900 0022
	2	1	2	07 31 900 0021

## Dimensions

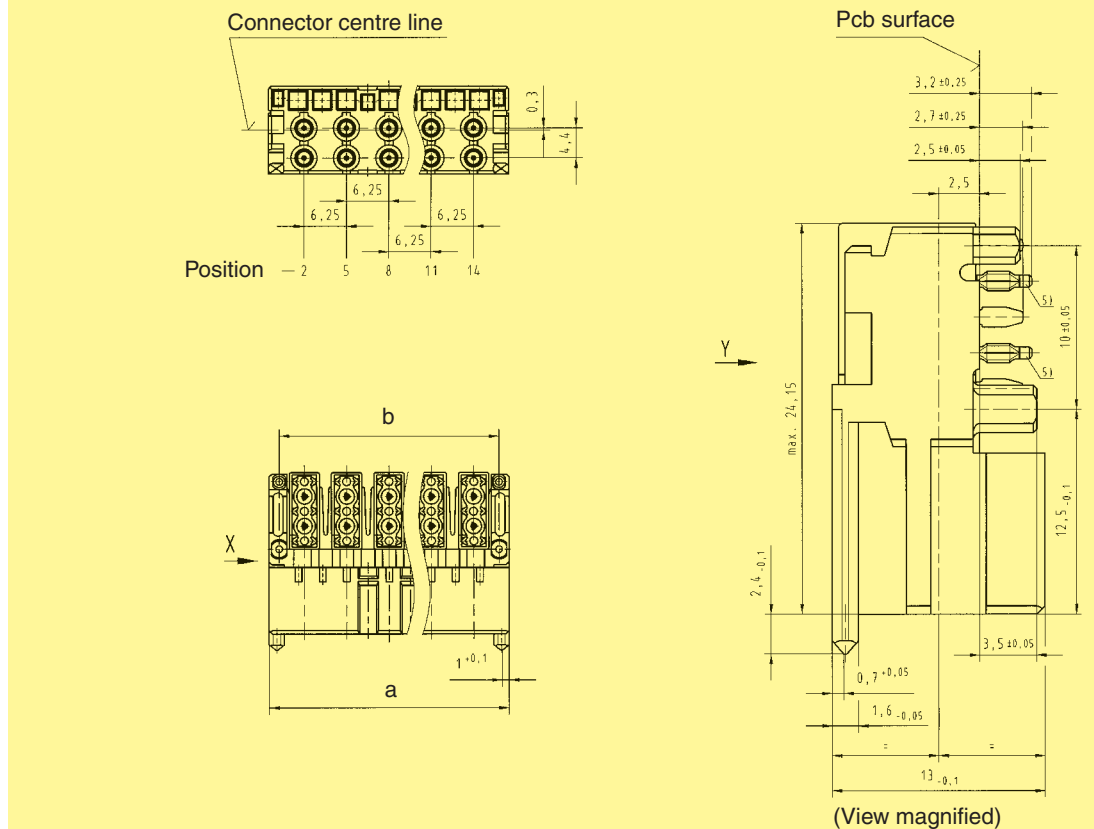

## Board drillings

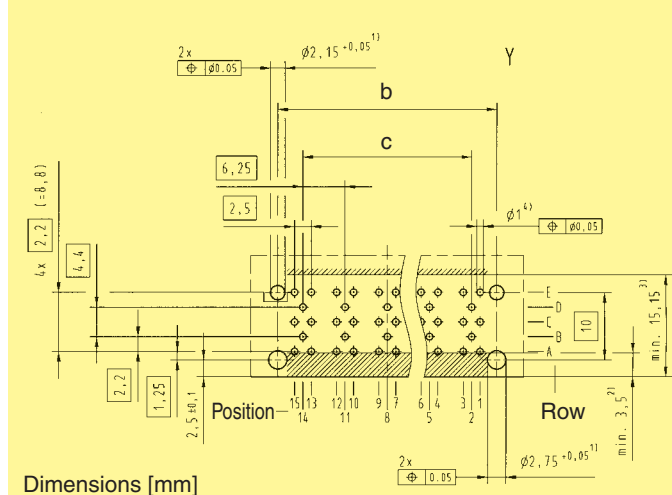

Angled module	Dimension [mm]		
	a	b	c
1.50 SU	35.45	32.5	25
1.25 SU	29.15	26.25	18.75
1.00 SU	22.9	20	12.5

Row B, D: position 2, 5, 8, 11, 14 for signal line  
 Row A, C, E: position 1, 3, 4, 6, 7, 9, 10, 12, 13, 15 for ground-line

- 1) Non-metallised drillings
- 2) No tracks, except solder eyes
- 3) Limit area of components (valid for both pcb-sides)
- 4) Details see page 10.07
- 5) Press-in zone in any angular position related to it's longitudinal axis possible

Dimensions [mm]



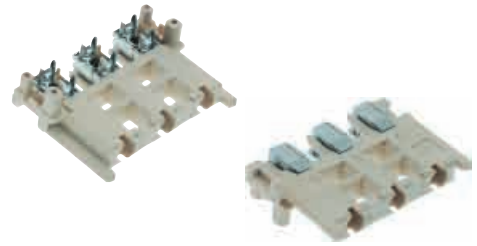

### Angled modules

Identification	Number of contacts	SU	loaded positions	Part number
Mini Coax single-row module, press-in termination	3	1	2, 5, 8	07 31 100 0028

### Dimensions

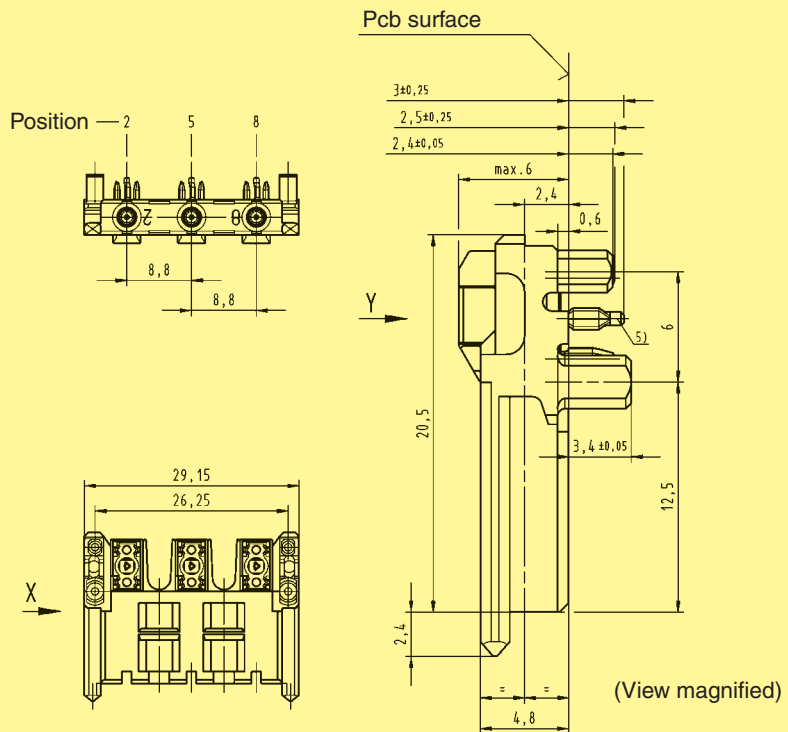

### Board drillings

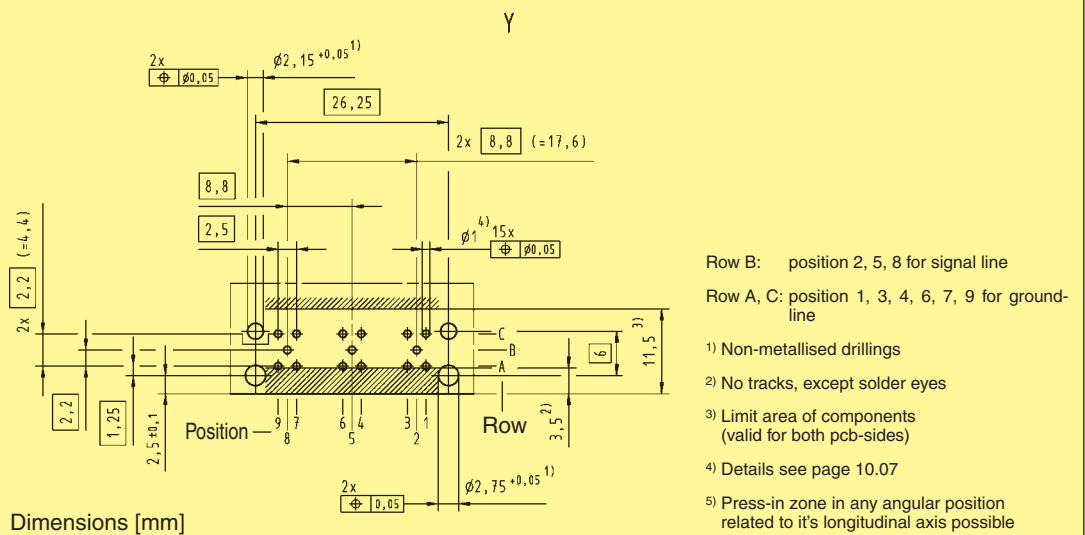

Dimensions [mm]



The Mini Coax product range also includes various cable assemblies and accessories, which provide customers with flexible application options.

The Mini Coax cable connector is available as plug and socket and is crimped to a coaxial cable that can be individually assembled with RF-cable connectors (SMA, SMB, N-type ...). While delivering high RF transmission performance, the moulded Mini Coax cable assemblies provide robust connections. The various angle mould types meet different cable routing requirements according to the available space.

Thanks to various accessories, such as backplane frame, Han® housing insert and press-in cable housing ..., customized connecting requirements can be met.

Remark:

The cable assemblies and accessories shown are part of the overall product range.

**Additional, customized parts are available on request.**



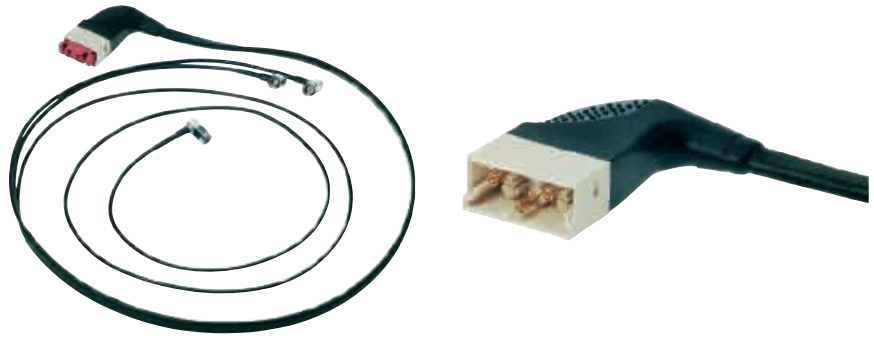

## Cable assemblies

Identification	Number of contacts	Part No.	Drawing	Dimensions [mm]
Cable assembly for mating with the angled standard module	1-10	on request		
Cable assembly for mating with the angled low-profile module	1-6	on request		



Assemblies with single-row modules and hoods/housings

Identification	Number of contacts	Part No.	Drawing	Dimensions [mm]
Cable assembly for mating with the angled single-row module	1-3	on request		
Cable assembly with heavy duty hoods/housings	1-10	on request		



## Accessories

Identification

Part No.

Backplane frame

07 71 100 0042

## Dimensions [mm]

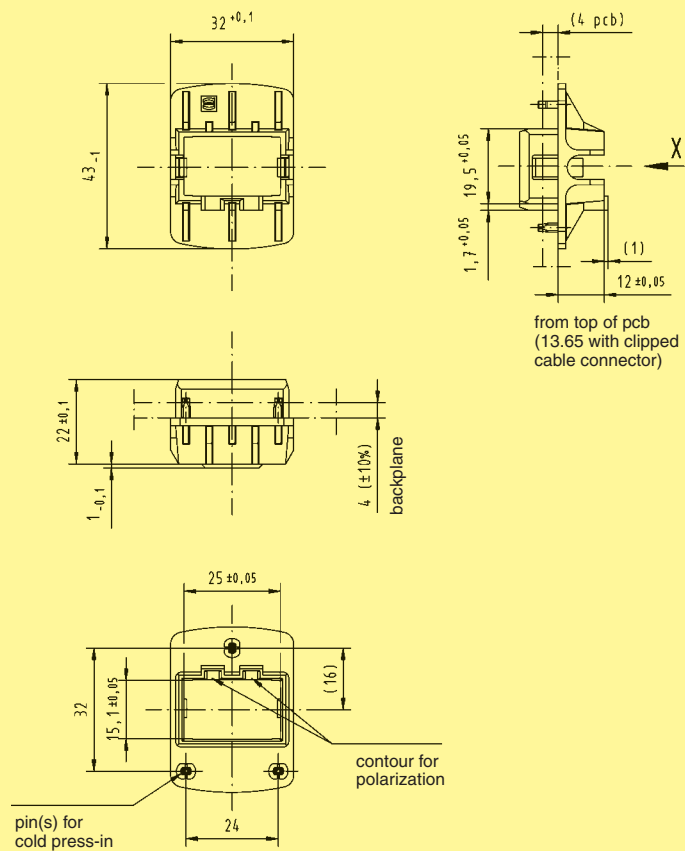

## Board drillings

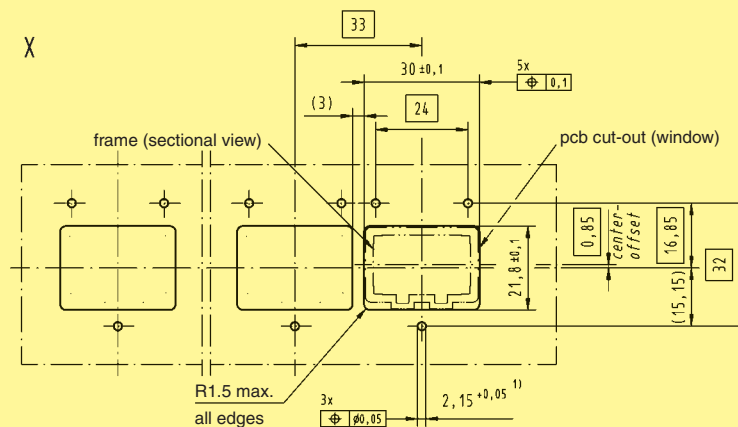

1) Non-metallized drillings